



**GROUP 721** **PAINTS**



Page ..... **625**

**GROUP 727** **CLEANING BATHS**



Page ..... **626,627**

**GROUP 727** **SOLVENT DEGREASERS**



Page ..... **626**

**GROUP 732** **CLEANER SPRAYS**



Page ..... **628**

**GROUP 732** **MAINTENANCE SPRAYS & LUBRICANTS**



Page ..... **628-631**

**GROUP 734** **MARKERS - LINE & PAINT**



Page ..... **632**

**GROUP 740** **GREASES & OILS**



Page ..... **633-634**

**GROUP 740** **FOOD INDUSTRY**



Page ..... **636,637**

**GROUP 741** **SECONDARY CONTAINMENT STORAGE**



Page ..... **638-640**

**GROUP 742** **SPILL RESPONSE**



Page ..... **640-643**

**GROUP 780** **HAND & SKIN CARE**



Page ..... **644-646**

**GROUP 780** **CLEANING PRODUCTS**



Page ..... **647-649**

**GROUP 708** **HOT DIP**



Page ..... **624**

**GROUP 716** **SEALANTS & ADHESIVES**



Page ..... **624**

# SECTION 7 Contents



## LUBRICANTS & CHEMICAL PRODUCTS

**Section 7**  
**Product Groups**  
**708 - 780**

### Product Grading



**Production**



**Professional**



**Industrial**



**Workshop**



**Maintenance**



**Home Improver**

Description	Group	Page
Cleaning Products	780	<b>626,647-649</b>
Cleaner Sprays	732	<b>628,647,648</b>
Cleaning Baths	727	<b>626-627</b>
Fire Blankets	714	<b>24</b>
Food Industry	740	<b>636-637</b>
Hand & Skin Care	780	<b>644-646</b>
Hot Dip Coatings	708	<b>624</b>
Maintenance Sprays & Lubricants	732	<b>628-631</b>
Markers - Line & Paint	734	<b>632</b>
Metal Cutting Lubricants	740	<b>634</b>
Oils & Greases	740	<b>633</b>
Paints	721	<b>625</b>
Screen Wash	732	<b>631</b>
Sealants & Adhesives	716	<b>624,625</b>
Sealant Applicator Guns	715	<b>624</b>
Secondary Containment Storage	741	<b>638-640</b>
Solvent Degreasers	727	<b>626</b>
Spill Response	742	<b>640-643</b>



**Protective Coating  
Red-Hot-Dip**

Hot dip strippable plastic coating moulds itself around the component or tool being coated to provide 100% coverage and protects against corrosion and impacts, for up to ten years. The component protected can be easily identified through the translucent coating. Simply removed by peeling it off, leaves behind a thin oil film to provide short term protection against corrosion. The removed protective dip can be reused. Never directly apply heat to melt the protective dip, always use with a suitable melting pot. Working temperature 130°C to 160°C (for optimum results 140°C to 145°C).

**AD160**  
Amber



**RD160**  
Red



Description (Bars)	Weight each	Order Code <b>KEN-708</b>
RD160 Single Bar	0.50kg	<b>-0050K</b>
RD160 Case (50)	25.00kg	<b>-0250K</b>
AD160 Single Bar	0.50kg	<b>-0500K</b>
AD160 Case (50)	25.00kg	<b>-0550K</b>

**Industrial Melting Pots**

A range of melting pots which have been designed for industrial melting of waxes, glues and plastics etc. for coating, casting, protecting etc. The pots are electrically heated and thermostatically temperature controlled from 50°C to 200°C. Constructed from anodised aluminium with ceramic fibre insulation. Pots supplied with 2m cable and fused plug, lifting handle, double-wall heat-conserving lid, on/off switch and safety thermal cut-out. 220/240V as standard.



Capacity		Internal Dimensions		Maximum Wattage	Order Code <b>KEN-709</b>
Litres	Pints	Diameter	Depth		
0.7	1.20	100mm	90mm	275	<b>-1010K</b>
2.5	4.40	150mm	140mm	600	<b>-1030K</b>
6.0	10.5	200mm	190mm	1125	<b>-1060K</b>
12.0	21.0	250mm	240mm	1650	<b>-1120K</b>
20.0	35.0	300mm	290mm	1975	<b>-1200K</b>



**Fire Blankets**

Fire blanket supplied in a quick release dispenser which can be attached to a wall near possible fire hazards. The blanket is manufactured from neoprene coated glass cloth. Conforms to **BS6575 1985** light duty. **B.A.F.E. approved**, Kitemarked to **BS EN1 869: 1997**. Independently tested by the Loss Prevention Council. Guaranteed for five years.



**NEW**

Blanket Size	Order Code <b>TFF-714</b>
1.2m x 1.2m	<b>-3000K</b>
1.8m x 1.2m	<b>-3020K</b>
1.8m x 1.8m	<b>-3040K</b>

**SHERLOCK Non-Setting Sealant**



**Gas Seal**  
Non-setting, off-white compound for use on metallic threaded and face joints carrying gas including aluminium, copper, steel and zinc. Suitable for use with propane, butane, LPG and natural gas.  
**Temperature range:** -20°C to +125°C. Gas  
**Maximum gas pressure:** 2.9psi (0.2bar).

**NEW**



**400g TIN**

Size	Order Code <b>SHK-720</b>
400g	<b>-4010K</b>



**Silicone Sealants**



**General-Purpose Silicone**

High performance acetoxysilicone provides a permanently watertight flexible seal and offers excellent adhesive properties, making it suitable for use on glass, sanitary-ware, ceramics and non-porous surfaces. For indoor and outdoor use. Weather-proof. Mould-resistant. Life expectancy up to 25 years. Conforms to **BS 5889**.  
**Size:** 310ml cartridge.



Colour	Order Code <b>SHK-716</b>
White	<b>-3100K</b>
Clear	<b>-3110K</b>
Black	<b>-3130K</b>
Grey	<b>-3140K</b>



**Sealant Cartridge Applicator Guns**



**Economy Plastic Gun - C3**

Robust, easy to use. Smooth action.

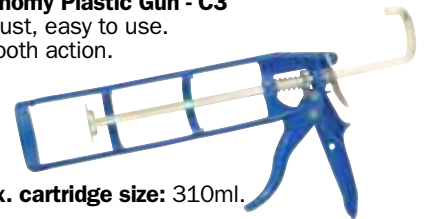

**Max. cartridge size:** 310ml.

Type	Cartridge (max size)	Order Code <b>KEN-715</b>
C3	310ml	<b>-1200K</b>

**Professional Metal Guns**

Extremely robust and ideal for continuous use. Will not twist under pressure.



Smooth action for optimum application of sealant.

Type	Cartridge (max size)	Order Code <b>KEN-715</b>
C3	310ml	<b>-1000K</b>
C4	400ml	<b>-2000K</b>

**Ergonomic Sealant Applicator Gun**

**Heavy-Duty Metal Gun - C3**

Extremely robust and ideal for continuous use. Ergonomically designed.



Smooth action for optimum application of sealant.

Type	Cartridge (max size)	Order Code <b>KEN-715</b>
C3	310ml	<b>-1400K</b>

**LUBRICANTS & CHEMICAL PRODUCTS**

**SOLENT MAINTENANCE Floor Paint**

Attractive and hard wearing, transforms drab, stained or scuffed concrete and similar surfaces. Suitable for floors in warehouses, workshops, shop floors garages, basements, etc.

**Coverage:** up to 8m<sup>2</sup>/ltr (two coats recommended).

Please note, colours are for guidance only.



Colour	Size	Order Code
		<b>SOL-721</b>
Mid Grey	5ltr	<b>-2050E</b>
Tile Red		<b>-2100K</b>
Mid Green		<b>-2030C</b>
Dark Grey		<b>-2040D</b>
Mid Blue		<b>-2060F</b>
Safety Yellow		<b>-2120K</b>

**Anti-Slip Floor Paint**

**Tuffgrip**

Solvent free industrial quality floor paint. Applied by roller as a one-coat system, to provide traction in areas of slip hazard. Hard wearing, epoxy resin anti-slip coating suitable for use on heavy trafficked concrete, stone, steel and wooden floor surfaces.

**Coverage:** 5m<sup>2</sup> per pack.

Please note, colours are for guidance only.



Colour	Order Code
	<b>SOL-721</b>
Mid Grey	<b>-3050E</b>
Safety Yellow	<b>-3080H</b>
Tile Red	<b>-3100K</b>

**Enamel Paint**

This tough enamel has long lasting flexibility when used to cover rust, bare metal and wood, repelling moisture to give long term protection.

It must be applied in temperatures of 5° C or above and is sag resistant to eliminate brush strokes, dilutable by white spirit and can be used for interior or exterior applications.



RAL	Colour	Size	Order Code
			<b>SOL-721</b>
<b>9005</b>	Black	1ltr	<b>-6110A</b>
		2.5ltr	<b>-6110C</b>
		5ltr	<b>-6110E</b>
<b>5012</b>	Blue	1ltr	<b>-6112A</b>
		2.5ltr	<b>-6112C</b>
		5ltr	<b>-6112E</b>
<b>6010</b>	Green	1ltr	<b>-6114A</b>
		2.5ltr	<b>-6114C</b>
		5ltr	<b>-6114E</b>
<b>3000</b>	Red	1ltr	<b>-6117A</b>
		2.5ltr	<b>-6117C</b>
		5ltr	<b>-6117E</b>
<b>9010</b>	White	1ltr	<b>-6118A</b>
		2.5ltr	<b>-6118C</b>
		5ltr	<b>-6118E</b>
<b>1007</b>	Yellow	1ltr	<b>-6120A</b>
		2.5ltr	<b>-6120C</b>

**SHERLOCK Instant Nails**

A high strength gap filling solvent-free adhesive that produces a quick 'grab' and replaces mechanical fixings in a multitude of home improvement applications. Dries white and is over-paintable when dry.



**Instant Adhesive**

High performance cyanoacrylate adhesive suitable for use on metal, plastic, china, leather, wood, glass and rubber. Bonds in seconds.

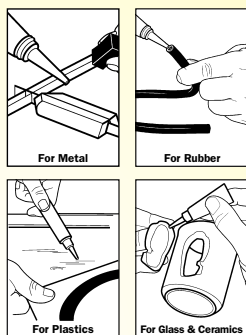

Size	Order Code
	<b>SHK-725</b>
3g	<b>-6010K</b>

**Rust Covering Enamel Paint**

High gloss rust covering enamel paint. Corrosion resistant, can be applied directly to rusty metal and repels moisture providing long term protection. Touch dry in 20 mins (subject to humidity and temperature), no need for primer or undercoat.

**Coverage:** 0.6m<sup>2</sup> per 500ml can.



**500ml CAN**

**500ml Aerosol Can**

Colour	Size	Order Code
		<b>SOL-721</b>
Black	Hammer	<b>-5210A</b>
Silver/Grey	Hammer	<b>-5310L</b>
Black	Smooth	<b>-5010A</b>
Blue	Smooth	<b>-5020B</b>
Red	Smooth	<b>-5100K</b>
Silver/Grey	Smooth	<b>-5110L</b>
White	Smooth	<b>-5130N</b>
Yellow	Smooth	<b>-5140P</b>



Size	Order Code
	<b>SHK-725</b>
310ml	<b>-6500K</b>

**KENNEDY P.T.F.E. Tape**

**Gas Type:** 12mm x 5m roll. For gas and hot water pipes (not for potable water). Made to **BS EN 751:3**.

**Water Type:** 12mm x 12m roll. For hot and cold water pipes. Made to **BS 6920 & BS 7786**.

**PTFE Thread Sealing Tape:** 25mm x 12m roll. Made to **EN571**.



Description	Order Code
	<b>KEN-983</b>
Gas	<b>-8000K</b>
Water	<b>-9000K</b>
Thread Sealing Tape	<b>-9010K</b>



**Just Orange**

**Citrus-Based Solvent Degreaser**

Just Orange is a safe but powerful, citrus-based solvent degreaser. For the cleaning and degreasing of engineering components and equipment. Safely removes heavy oils, greases, bitumen, wet paints, adhesives and sealants from virtually all hard surfaces. Non-toxic, contains no CFCs. Reduced VOC. Inflammable. Non-hazardous for waste disposal. Can be used as a safer, environmentally friendly alternative to hazardous solvents such as acetone, benzene, butyl cellulose, CFCs, freon, glycol ethers, HCFCs, isopropyl alcohol, methyl ethyl, ketone, mineral spirits, toluene, trichloroethylene, xylene etc.



**Orange Plus**

**Citrus-Based Water Rinseable Degreaser**

Orange Plus is a safe but powerful, citrus-based solvent degreaser. For the cleaning and degreasing of engineering components and equipment. Safely removes heavy oils, greases, bitumen, wet paints, adhesives and sealants from all metals, including plant and machinery, and some plastics. Non-toxic, contains no CFCs. Reduced VOC. Non-flammable. Non-hazardous for waste disposal. Can be used as a safer, environmentally friendly alternative to hazardous solvents such as Xylene, Toluene, Acetone etc.



**Aqueous Orange**

**Citrus-Based Aqueous Cleaner**

Aqueous Orange is a highly concentrated citrus-based blend of solvents and powerful surfactants will safely remove oils, greases etc from many hard surfaces. Designed to replace hazardous solvents such as white spirit and paraffin. It can be diluted with water for maximum economy and its micro-emulsion formula offers the benefits of both water-based economy with solvent based efficiency. Contains biodegradable surfactants which enable it to break down naturally after disposal. Non-toxic, contains no CFCs. Negligible VOC. Non-flammable. Non-hazardous for easy waste disposal. Can be used as a safer, environmentally friendly alternative.



**LUBRICANTS & CHEMICAL PRODUCTS**



Size	Order Code
1ltr	<b>-2800A</b>
5ltr	<b>-2810B</b>
20ltr	<b>-2820C</b>



Size	Order Code
5ltr	<b>-2910B</b>
20ltr	<b>-2920C</b>



Size	Order Code	
5ltr	<b>-2610B</b>	N/A
20ltr	<b>-2620C</b>	N/A

**Degreasing Station/Parts Washer**

Air operated, strong and durable mild steel degreasing station. Ideal for use as a soaking bath and air agitation facility aids the degreasing process by removing heaviest oil and grime from small parts. Also comes with a flow through brush to deal with caked on grime. Designed to sit on 100ltr barrel.

**Dimensions:**

**Length:** 760mm (30").

**Width:** 510mm (20").

**Height:** 200mm (8").

**Weight:** 20.8kg.

**Working height:** When on 100ltr drum = 890mm (35").

**Solvent delivery:** Flow through brush.

**General:**

Powder coated bowl and galvanised splashback sheet.

Tray is mild steel.

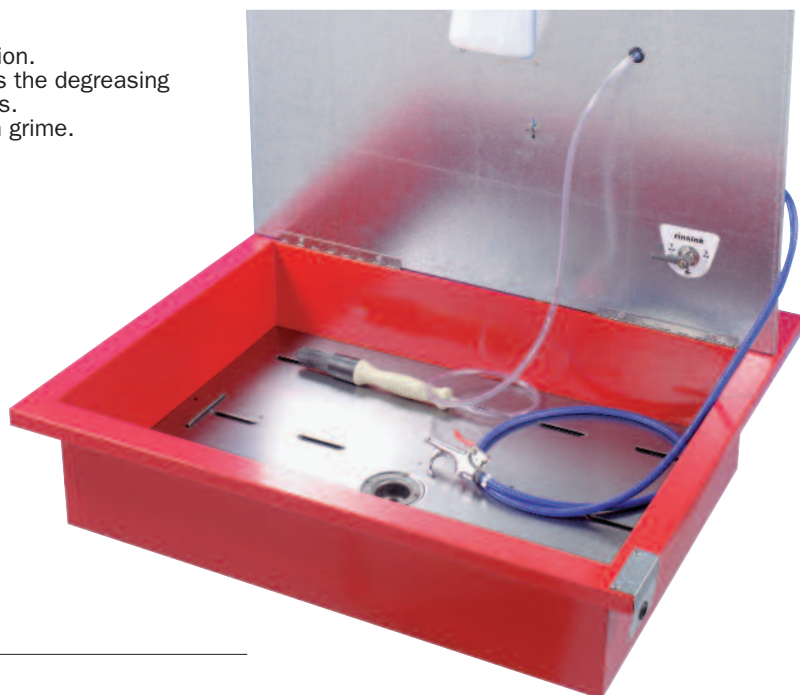

Tray Material	Voltage	Order Code
Mild Steel	110V Parts Washer	<b>-5110A</b>
Mild Steel	240V Parts Washer	<b>-5240A</b>



**KENNEDY** *Parts Washer - Bench Standing*  
QUALITY INDUSTRIAL TOOLING

Used in garage, workshop and industrial applications for degreasing components for inspection and prior to assembly. Recirculated cleaning fluid is filtered before entering the pump and being directed over the work piece. Flexible chrome finish metal delivery hose. Heavy duty non-welded one piece tank. Fully enclosed electric nylon pump. Self-latching fusible linked lid closes in the event of a fire. Triple baked enamel finish. Accepts all common degreasing agents. Shelf keeps parts out of solvent during inspection and drying. Immersion soaking when the parts shelf is removed. Fitted with a 3 pin moulded plug and a 1.6m power cable. Minimum agent capacity 9ltr. Maximum agent capacity 13ltr. Rubber feet. 240V.

**Overall size (L x W x H):** 470 x 340 x 250mm.  
**Tank size (L x W x H):** 400 x 310 x 230mm.  
**Power rating:** 25W.  
**Voltage:** 240V.  
**Rated input:** 0.3A.  
**Net weight:** 6.5kg.



Model Number	Weight each	Order Code
PWB013	7.60kg	<b>KEN-503</b> <b>-8600K</b>

**Parts Washer - Floor Standing**

Used in garage, workshop and industrial applications for degreasing components for inspection and prior to assembly. Recirculated cleaning fluid is filtered before entering the pump and being directed over the work piece. Flexible chrome finish metal delivery hose. Heavy duty non-welded one piece tank. Fully enclosed electric nylon pump. Self-latching fusible linked lid closes in the event of a fire. Triple baked enamel finish. Accepts all common degreasing agents. Shelf keeps parts out of solvent during inspection and drying. Immersion soaking when the parts shelf is removed. Fitted with a 3 pin moulded plug and a 1.6m power cable. Minimum agent capacity 40ltr. Maximum agent capacity 50ltr. Fitted with a drain plug for easy maintenance. Removable parts basket. Built in replaceable filter. Spare filter included.

**Overall size (L x W x H):** 800 x 550 x 890mm.  
**Tank size (L x W x H):** 725 x 490 x 270mm.  
**Height of working area:** 750mm.  
**Power rating:** 25W. **Voltage:** 240V.  
**Rated input:** 0.3A.  
**Net weight:** 31kg.



Model Number	Weight each	Order Code
PWF050	34.5kg	<b>KEN-503</b> <b>-8640K</b>

**Replacement Parts**

Description	Order Code
Filter for PWF050	<b>-8640K</b>
Filter for PWB013	<b>-8600K</b>
Pump for PWF050/PWB013	<b>-8700K</b>

LUBRICANTS & CHEMICAL PRODUCTS

**GROUP 732 MAINTENANCE SPRAYS & LUBRICANTS**

**SITESAFE Cold Galvanising Spray**

**CGA500**

Fast drying corrosion protection. Matches colour of newly galvanised metal. Ideal for protecting welding joints in galvanised structures. Can be used as a top coat or primer. Compatible with most paint finishes. Contains no CFCs or lead. Fitted with directional spray button designed to assist application in outdoor locations with minimum over-spray.



500 ml

Product Number	Size	Order Code
CGA500	500ml	<b>-3900K</b>

**SOLENT MAINTENANCE Galvanising Spray**

**Cold Zinc - SZ1-500B**

Fast drying corrosion protection. Matches colour of newly galvanised metal. Ideal for protecting welding joints in galvanised structures. Can be used as a top coat or primer. Compatible with most paint finishes. Contains no CFCs or lead. Fitted with directional spray button designed to assist application in outdoor locations with minimum over-spray.



500 ml

Product Number	Size	Order Code
SZ1-500B	500ml	<b>-0900K</b>

**Multi-Purpose Oil Spray CO<sub>2</sub>**

**SM3-500C**

Multi-purpose mineral lubricating oil formulated to have a wide operating range. It lubricates, penetrates, cleans and protects. Use on locks and hinges. Cleans and protects tools. Helps to release stubborn and rusted bolts. Outdoor protection making it ideal for boats. Suitable for household use yet strong enough for industrial applications. Contains a special blend of anti-rust agents which will protect all treated surfaces against corrosion. Does not contain silicone or CFCs.



**NEW**

**IMPROVED FORMULA**

Product Number	Aerosol Size	Order Code
SM3-500C	500ml	<b>-0450K</b>

**LUBRICANTS & CHEMICAL PRODUCTS**

**Trike-free Contact Cleaner**

**CCA500C Electrical Contact Cleaner Spray - Trike-free**

Suitable for cleaning and degreasing delicate components such as those used in electrical equipment. It can be used on most surfaces and will not effect PCBs, delicate plastics or painted surfaces. Non-corrosive. It contains only solvents which are permitted under the Montreal Protocol.



Product Number	Size	Order Code
CCA500C	500ml	<b>-3120K</b>

**Cleaner Spray**

**SC2-500C Electrical Contact Cleaner Spray - Trike-free**

An effective solvent based cleaner. The product is formulated to remove oil, grease and carbon dust from electrical switch gear and electronic components. It is safe on most common plastic parts, but will attack lacquer finishes and coatings. If in doubt about suitability, trial the product on a scrap sample first before general application. The product is propelled from the aerosol by CO<sub>2</sub> carbon dioxide gas (non-flammable). Electrical Switch Cleaner fluid is flammable. Always ensure power is switched off before applying this product to electrical equipment.



Product Number	Size	Order Code
SC2-500C	500ml	<b>-0120K</b>

**Cleaner Spray**

**SC1-500B Industrial Rapid Dry**

Solent rapid dry solvent cleaner is supplied in a large 500ml aerosol. The product is formulated to quickly penetrate grease, oil and general soiling from metal/electrical components and precision parts. The formulation rapidly evaporates leaving a clean, dry surface. Very effective at temperatures ranging from -5°C to 30°C. Safe on most plastic components. Will soften some lacquers. If in doubt about suitability test on a scrap component or a small area before general application.



Product Number	Size	Order Code
SC1-500B	500ml	<b>-0100K</b>

**Anti-static Foam Cleaner**

**FCA500**

This cleaner is recommended for the everyday cleaning of electronic and electrical equipment. It removes stubborn stains, nicotine, grease and general grime build-up from plastic, formica, leatherette, ceramics, glass, paintwork or any other non-porous hard surface. Ideal for use in offices, canteens, banks, schools, kitchens, washrooms and many other problem areas. It has been formulated from surfactants and solvents which are safe to use on most surfaces.



Container Type	Size	Order Code
Aerosol	500ml	<b>-3180K</b>

**Foaming Spray**

**SC5-500B**

Cuts through grease, dirt, oil and general soiling, contains no silicones. Ideal for non-porous surfaces. 1000+1 uses in the home, industry, garage or factory.



Container Number	Size	Order Code
SC5-500B	500ml	<b>-0180K</b>

**KENNEDY Air Lube Oil**

Excellent air release quality, low foaming ability and resists clogging. Contains anti-rust and anti-wear additives. Extremely resistant to water absorption and can be mixed with all mineral oil based lubricants without draining the system. Can be used on air tools. **ISO Grade VG22.**



Container Type	Size	Order Code
Poly Bottle	500ml	<b>-8000K</b>



**Silicone Release Spray**

**SR2-500B - Heavy Duty**

Heavy duty silicone lubricant and release agent. Formulated with a high silicone content. The product is suitable for a wide range of uses. SR2-500B is a dry non-oily, non-greasy product. Water clear with no odour.



Product Number	Size	Order Code
SR2-500B	500ml	<b>-0720K</b>

**Silicone Release Spray**

**SR1-500B - for Plastics & Rubber**

Heavy-duty silicone lubricant and release agent. Formulated with a high silicone content. The product is suitable for a wide range of uses. SR1-500B is a dry non-oily, non-greasy product. Water clear with no odour.



Product Number	Size	Order Code
SR1-500B	500ml	<b>-0700K</b>

**Maintenance Spray**

**SM4-500C 'M4 Plus'**

**Lubricates:**

High performance mineral oil based lubricant with PTFE.

**Displaces Water:**

Helps start damp engines.

**Penetrates:**

Releases rusty fixings.

**Cleans & Protects:**

Cleans metal surfaces and prevents rusting of treated parts.

Does not contain naphtha, kerosene or paraffin which are all associated with operator skin dryness, cracking or dermatitis. CO<sub>2</sub> non-flammable propellant. Does not contain silicone. Electrically non-conductive at normal ranges found in the home. Care must be taken if used on some electrical plastic components where 'crazing' may occur.



Product Number	Size	Order Code
SM4-500C	500ml	<b>-0460K</b>

**Anti-Rust Protection Spray**

**SP1-500B - Green**

Solent green moisture guard is a soft thin film moisture/corrosion protective coating. Packed in a large 500ml aerosol. The coating has a slight green colouring which clearly indicates treated areas. Ideal for longer term moisture/ corrosion protection of machined components/ moulding dies and tools. Removed easily with Solent Industrial Cleaner, part number SC1-500B.



Product Number	Size	Order Code
SP1-500B	500ml	<b>-0600K</b>

**Heavy Duty Anti-Rust Protection Spray**

**SP2-500B**

Solent heavy-duty anti-rust protection spray is a high performance corrosion inhibitor. The product is sprayed directly onto the surface to be protected. Clear in colour with a faint yellow trace to identify treated surfaces. The film has self-healing properties and is easily removed with solvent cleaners. The coating will resist moisture, acid and alkali fumes. The film does not contain silicone or halogens. Corrosion protection periods vary with environmental conditions. Typical interior protection in the UK in excess of two years. Product can be re-applied should conditions require it.



Product Number	Size	Order Code
SP2-500B	500ml	<b>-0620K</b>

**Mould Release Dry Film PTFE Lubricant**

**SR3-500B**

Provides a micro-thin surface coating for the inner surfaces of injection moulding tools/dies, thus enabling easy component release. The coating will not bridge complex mould profiles and will not interfere with precision fits. The applied PTFE film will not transfer to the moulded item and can be used where a dry slip surface is required such as production line slides, tracks or tables.



Product Number	Size	Order Code
SR3-500B	500ml	<b>-0740K</b>



**Penetrating Spray**

**POA500**

Penetrating oil for dismantling, lubricating and cleaning. This oil displaces water leaving a hydrophobic coating to protect surfaces from corrosion. It penetrates threads and crevices to release and lubricate delicate mechanisms, pivot points and sliding surfaces whilst degreasing hard surfaces.



Container Type	Size	Order Code
Aerosol	500ml	<b>-3400K</b>

**Penetrating Spray**

**SM1-500B**

Rapidly penetrates into rust and corroded fittings. Allows easy release and dismantling of fittings exposed to heat and great pressure. Can be used on wet metal components, does not contain silicone, CFCs or chlorine. Lubricates threads during release procedure, 30% less dense than water.



Product Number	Size	Order Code
SM1-500B	500ml	<b>-0400K</b>

**LUBRICANTS & CHEMICAL PRODUCTS**

**SITESAFE Leak Detector Spray**

**LDA500**  
For checking for the most minute leaks in any gas or air pressurised systems including commercial vehicle air brakes and pressure vessels. Contains no alcohols or solvents, is not caustic and contains a rust inhibitor. Spray directly onto the suspect area using the extension tube and examine for bubbling which will indicate leakage.



Container Type	Size	Order Code
Aerosol	500ml	<b>SF-732</b>
		<b>-3340K</b>

**SOLENT MAINTENANCE**

**Leak Detector Spray**

**SL1-400A**  
A specially formulated, performance white fluid, designed to identify even the smallest gaseous leak. Applies a thin uniform film of surface active agents which identifies any leak or bleeding of joints, bubbles in the film indicate the location of the leak. Will not give a false reading if mechanical sensing equipment is used. Suitable for use with most common gases including compressed air, acetylene, butane, propane, chlorine, hydrogen and natural gas.



Product Number	Size	Order Code
SL1-400A	400ml	<b>SOL-732</b>
		<b>-0340K</b>

**3-Part Flaw Inspection System**

Fast reliable method for visually inspecting and spot-checking surfaces of welds, exotic alloys or standard metals, highly stressed structural members, critical castings, shafts, gears, spindles, and any other hard part where identification of surface flaws is essential. Detects flaws such as cracks, pin holes, welding laps and porosity either during manufacture or on-site.



**Flaw Detector Cleaner Spray**

**SF1-500B**  
Quick drying, powerful solvent for cleaning surfaces prior to testing. Removes contaminants including oils, greases and grime.



**BIG VALUE 500ml Can!**

Product Number	Size	Order Code
SF1-500B	500ml	<b>SOL-732</b>
		<b>-0240K</b>

**Flaw Detector Dye Penetrant**

**SF2-500B**  
Highly sensitive red dye, for use when detecting flaws on metal components under normal lighting conditions.



**BIG VALUE 500ml Can!**

Product Number	Size	Order Code
SF2-500B	500ml	<b>SOL-732</b>
		<b>-0260K</b>

**Flaw Detector Developer**

**SF3-500B**  
White film to highlight any faults which have been detected when using Flaw Detector Penetrant. The product should be removed using Flaw Detector Cleaner Spray once cracks have been found and marked.



**BIG VALUE 500ml Can!**

Product Number	Size	Order Code
SF3-500B	500ml	<b>SOL-732</b>
		<b>-0280K</b>

**LUBRICANTS & CHEMICAL PRODUCTS**

**Copper Grease Spray**

**SM7 500B - With Graphite**  
Components subjected to great heat and pressure during their operating life can easily be dismantled if Copper Spray Grease is applied during assembly. Grease melts at high temperatures and disappears, but copper stays put. e.g. to lubricate the threads on exhaust assemblies etc. Copper grease spray is particularly effective on commercial/passenger vehicle braking systems. Extra heavy-duty copper grease with graphite. High copper content - effective up to 1100°C. No lead content/no CFCs/no silicone/no chlorinated content.



Product Number	Size	Order Code
SM7-500B	500ml	<b>SOL-732</b>
		<b>-0520K</b>

**Welder's Anti-Spatter Spray**

Solvent-based coating applied to metal before welding. During welding small blobs of molten metal fall either side of the weld. These blobs are called spatter, this coating is applied before welding to prevent spatter from sticking to the metal. CO<sub>2</sub> propelled aerosol. Non-flammable. Silicone-free and removable with solvents prior to galvanising or painting.



Product Number	Size	Order Code
SW1-400C	400ml	<b>SOL-732</b>
		<b>-0840K</b>

**Dry Moly Spray**

**SD1-500B**  
Premium grade dry molybdenum particle lubricant. The dry coating can be polished (if required) to a high shine finish that provides excellent dry lubricant/slip/slide capabilities. Fast drying at room temperature. Ideal for fastener lubrication where it will prevent galling. Effective on all grades of steel, copper, brass, stainless steel and foundry equipment. Also for open gear lubrication and any location where a wet coating is not acceptable or would burn off. Works at up to load rates of 100,000psi. No silicone content.



Product Number	Size	Order Code
SD1-500B	500ml	<b>SOL-732</b>
		<b>-0200K</b>

**Maintenance Welder's Anti-Spatter Fluid**

Reduces the risk of joint puddling and greatly reduces preparation time prior to final painting. Does not affect any subsequent galvanising or painting operations. Evaporates under normal weld temperatures. Dichloromethane and silicone-free. Non-flammable, non-toxic, non-corrosive and biodegradable.



Size	Order Code
5ltr	<b>SOL-732</b>
20ltr	<b>-9300K</b>
	<b>-9310K</b>

**MAINTENANCE SPRAYS & LUBRICANTS/AUTOMOTIVE MAINTENANCE**



**Sherwood STD**

**Spray**  
400ml foam aerosol penetrates and is able to cling to normally inaccessible areas and moving cutting edges.



**Group 085**



Lubricant Type	Size	Weight per 12	Order Code
Spray	400ml	5.1kg	-4000K

**Sherwood STD Liquid (Poly Bottle)**

Low odour liquid. Coats the cutting edge with a film of EP additives.

**Sherwood STD Compound**

Low melting point paste maintains a continual lubricant feed to the cutting edge. Hand applied. Suitable for the most severe cutting operations.



Lubricant Type	Size	Order Code
Liquid	500ml	-4020K
Liquid	5ltr	-4060K
Compound	500g	-4040K

**STD Tapping & Drilling Non-Soluble Foam Lubricant**

Foam aerosol penetrates and is able to cling to normally inaccessible areas and moving cutting edges. Can be used on yellow metals without the risk of staining.



**NEW**

Lubricant Type	Size	Order Code
Foam	400ml	-4210K

**SOLENT™ Concentrated Screen Wash**

Solent™ screenwash can be used all year round and is the ideal way to keep your windscreen clean and clear of insects, road grime and traffic film. The anti-smear formula leaves a crystal clear windscreen with every wash and resists freezing, ideal for winter motoring. Contains water softeners.



**NEW**

Product	Size	Order Code
Concentrated Screenwash	5ltr	-9400K
	25ltr	-9420K



**Chain & Drive Spray Lubricant**

**SM6-500B**  
Formulated to have a wide range of operating uses. Ideal lubricant for moving chains under extreme load and for chains not fitted with automatic lubrication nor running in oil baths. Formulated with a 'tacky additive' to resist 'throw off' on rapidly moving chains and drives. Ideal for fork trucks/conveyer systems/motorcycle chains. Can be used as a slideway lubricant for machine tools. Strong anti-rust qualities. Does not contain silicone or CFCs.



Product Number	Size	Order Code
SM6-500B	500ml	-0500K

**Drive Belt Dressing Spray**

**SB1-500B**  
Reduces slip on drive belts and helps to stop belt squeal. Can be used on drive belts exposed to weather, ideal for farm machines, alternator drive belts and fan belts. Helps to stop cracking and extends belt life. Can be used on rubber, leather, canvas and most types of synthetic belts.



Product Number	Size	Order Code
SB1-500B	500ml	-0060K

**De-ionised Water DW25**

For use in lead-acid car batteries. Also suitable for domestic appliances such as steam irons and steam cleaners, avoids problems caused by scaling. Can be used as a final rinse in car washing to avoid 'spotting'. Also suitable for rinsing scientific glassware.



Size	Order Code
25ltr	-4250K



**Chain & Drive Spray**

**CCA500**

This product is a special blend of quality oils, greases and solvents, designed to lubricate and protect all types of cables and slow moving chains. It penetrates quickly into the centre of cables providing excellent protection to the core. It will not sling off, drip or dry out even in adverse conditions. It will also penetrate chain rollers and links enabling smoother working and reduce friction, wear and the possibility of seizure.



Container Type	Size	Order Code
Aerosol	500ml	-3500K

**Wire Rope Lube Spray**

**WRS500**

This spray lubricant has been formulated to lubricate and protect wire ropes from corrosion. It has good penetrative qualities to lubricate deep into the core of ropes, displacing water and increasing the life of the rope. 'Hi Tack' additives provide excellent adhesion to metal and reduced 'fling off' during use.



Container Type	Size	Order Code
Aerosol	500ml	-3450K

**EP Open Gear Spray**

**SM8-500B - with Molybdenum**

Solent EP Open Gear Spray lubricant is a premium extreme pressure lubricant packed in a 500ml aerosol. Based on molybdenum disulphide anti-wear additives. Suitable for lubricating all open gears where a thin film is specified. Suitable for temperatures as low as -40°C to +100°C.



Product Number	Size	Order Code
SM8-500B	500ml	-0540K

**LUBRICANTS & CHEMICAL PRODUCTS**

**GROUP 734 MARKERS - LINE & PAINT**

**KENNEDY Line Markers**  
QUALITY INDUSTRIAL TOOLING

For use on car parks, factory/ warehouse floors, playgrounds, sports fields, tennis courts, leisure centres and road surfaces. For stencils, line or free hand marking. CFC free formula, contains no lead additives.

Fully compatible with major brand applicators.

**Size:** 750ml can.



**750ml Can**

Please note, colours are for guidance only.

Colour	Application	Order Code KEN-734
White	General Marking	-6020K
Yellow	Hazard/ Caution	-6040K
Blue	Mandatory	-6060K
Red	Prohibition/Danger	-6080K
Green	Safe Condition/Direction	-6100K
Orange	Hazard/ Caution	-6120K
Black	Deletes Existing Lines	-6140K
Grey	Deletes Existing Lines	-6160K

**Line Marking Gun**

Manufactured from reinforced nylon. For offering trigger action to line marking spray cans, giving improved comfort during prolonged use.



Description	Order Code KEN-715
Line Marking Gun	-6200K

**SOLENT Line Markers**  
MAINTENANCE

Solent line marker is formulated with a high percentage of colour pigment which gives a bright easy to see finish and resists wear. Durable rapid drying formulation. Suitable for marking out car parks, factory/warehouse floors, playgrounds, sports fields, tennis courts, leisure centres and road surfaces. Can be used with stencils, line or free hand marking. CFC-free formula contains no lead additives. Fully compatible with major brand applicators. Each aerosol is supplied with an extra spray nozzle to ensure good spraying performance during the life of the aerosol.



**750ml Can**

Colour	Application	Order Code SOL-734
White	General Marking	-6020K
Yellow	Hazard/ Caution	-6040K
Blue	Mandatory	-6060K
Orange	Hazard/ Caution	-6120K

**Industrial Paint Markers**

Designed for countless metal marking applications. Can be used for marking greasy, rusty, or new metal surfaces. Also suitable for marking glass, plastic, wood, ceramics etc. Ballpoint nozzle cap will only allow ink flow when applied and pressed to the workpiece - ink cannot be spilt from the cap unintentionally. One head can be interchanged from differing inks and bottles. Can be refilled from one litre bulk refills of the specially formulated ink.



Please note, colours are for guidance only.



Colour	Size	Order Code KEN-734
Yellow	46ml	-3020K
White	46ml	-3040K
Blue	46ml	-3060K
Green	46ml	-3080K
Black	46ml	-3100K
Red	46ml	-3120K
Orange	46ml	-3140K

**Ink Refill Cases**

Colour	Size	Weight each	Order Code KEN-734
Yellow	1ltr	1.4kg	-3210K
White	1ltr	1.4kg	-3230K

**Ballpoint Head**

Replacement ballpoint head for Kennedy Industrial paint 46ml marker bottles.

Material	Ball Size	Order Code KEN-734
Nickel	2.4mm	-3500K



**Bullet Tipped Industrial Paint Markers**

For use on steel, aluminium, rubber, timber, plastic, ceramics and other materials. Bullet tipped. 2.3mm point size.



**NEW**



Colour	Order Code SOL-734
Black	-0010K
Blue	-0020K
Green	-0030K
Red	-0040K
White	-0050K
Yellow	-0060K

**STUARTS Micrometer Paste**

Oil-based paste for indicating high spots on machine bearings, machine tool beds etc. Easily removable with methylated spirit.



Colour	Pack Size	Order Code MIR-734
Blue	28g Tube	-8810B
	38g Tin	-8800A



**Slideway & General Purpose Lubricant Oil**

**Grade VG68**

Excellent lubricating properties under high pressure working conditions. Anti-wear additives to maximise machine tool life. Lubricates and flows freely even at very low temperatures. Eliminates slip stick and judder. Eliminates pick up and scoring.

**NEW**



Grade	Size	Order Code
VG68	20ltr	<b>-4368B</b>

**High Performance Hydraulic Oil**

**So-Hydra 'Plus' VG**

Excellent demulsifying properties (water and water containing fluids are rapidly separated). Very good corrosion protection to steel. Good corrosion protection to copper. High ageing stability/high oxidation stability. Good anti-wear protection. Very good hydrolytic stability. Excellent filtration behaviour. Low foaming. Excellent air release.

**NEW**



Grade	Size	Order Code
VG32	20ltr	<b>-4032B</b>
VG46	20ltr	<b>-4046B</b>
VG68	20ltr	<b>-4068B</b>
VG100	20ltr	<b>-4100B</b>

**Very High Viscosity Index Hydraulic Oil**

**So-Hydra 'Plus' VHV1**

Low foaming tendency. Good air release properties. High ageing stability/high oxidation stability. Good corrosion protection. Very good viscosity/temperature behaviour. Very good wear protection. High viscosity index. Wide service temperature range. Good shear stability.



**NEW**



Grade	Size	Order Code
VG68	20ltr	<b>-4168B</b>

**SOLENT+ Supergrade FS2™ Engine Oil**

**Semi-Synthetic 10W/40**

Refined mineral oil with special multifunctional synthetic additives: For all petrol, diesel and LPG cars, vans and lorries. For multi valve, fuel injected and turbo charged performance vehicles. Can be mixed with other oils. Assists easy engine starting in cold weather. Assists in reducing fuel consumption. Gives far greater protection against engine wear than non-synthetic oil. Excellent lubricity in all conditions. Excellent sludge control in 'stop-start' urban motoring conditions. Affords high protection at motorway speeds. Increased oil change intervals - change your oil less often. Meets the performance level requirements for: **API/SL/CH-4; Mercedes Benz 227.5; 229.1; 228.0/1; VW 501.01; 505.00, MAN 270/271.**

**NEW**



Grade	Size	Order Code
10W/40	5ltr	<b>-3010E N/A</b>

**Lithium Grease**

**So-Grease EP2**

High load lead-free lithium grease. Contains extreme pressure additives to allow use in heavy load conditions. Contains anti-rust additives to protect against corrosion. Anti-oxidants included to prolong product life. High ageing stability/high oxidation stability.

**NEW**



Type	Size	Order Code
Cartridge	400g	<b>-5100K</b>
Tub	5.00kg	<b>-5105C</b>
Pail	12.5kg	<b>-5110M</b>

**LUBRICANTS & CHEMICAL PRODUCTS**

**GROUP 740 METAL CUTTING LUBRICANTS**

**SOLENT+ LUBRICANTS** **Soluble Cutting Oil - Aluminium**

**So-Cool 'Plus' Aluminium**

Semi-synthetic, environmentally improved — does not contain sodium nitrite, phenols, triazene, PTBBA or chlorinated additives. Enhanced sump life and excellent anti-foam characteristics. Optimum tool life on the most arduous jobs. Excellent corrosion protection and lubrication to cutting areas, machine fixtures, slides etc. Low emulsion odour. Low drag out losses. Easily removed in splash areas. Resists the formation of aluminium soaps - Improves filtration and machine cleanliness.

**Recommended concentrations:**

General machining 7% or (a dilution of 14 to 1).  
Heavy-duty machining 10% or (a dilution of 10 to 1).

**NEW**



Grade	Size	Order Code
SC-ALU	20ltr	<b>-4533B</b>

**Soluble Cutting Oil - Cast Iron**

**So-Cool 'Plus' Iron**

Semi-synthetic formulation. Excellent anti-foam characteristics. Environmentally improved - does NOT contain sodium nitrite, phenols or chlorinated additives. Excellent sump life and corrosion protection. Superb tramp oil rejection characteristics. Enhanced tool tip life. Low drag-out loss - highly cost effective in use. Based on highly refined mineral oil. Increased detergency.

**Recommended concentrations:**

General machining 5% or (a dilution of 20 to 1).  
Arduous operations/difficult materials 7% or (a dilution of 14 to 1).  
Grinding 3% or (a dilution of 33 to 1).

**NEW**



Grade	Size	Order Code
SC-CAST	20ltr	<b>-4563B</b>

**Soluble Cutting Oil - Aerospace**

**So-Cool 'Plus' Aerospace**

Sophisticated lubricant chemistry. Excellent rust/staining protection. Low residue and good mix stability. Controls foam in high pressure fluid delivery applications. Outstanding bio-resistance. Excellent surface finishes and extended tool life. Preserves parts and equipment. Clean running operation. Specially formulated for use in both hard and soft waters. Extended service life/lower treatment costs.

**Recommended concentrations:**

General Machining 5% or (a dilution of 20 to 1).  
Heavy-duty machining 10% or (a dilution of 10 to 1).



**NEW**



Grade	Size	Order Code
SC-AERO	20ltr	<b>-4570B</b>

**LUBRICANTS & CHEMICAL PRODUCTS**

**Soluble Cutting Oil - Multi-purpose**

**So-Cool 'Plus' GP**

Environmentally improved - does NOT contain phenols, boron, triazene, PTBBA or chlorinated additives. Based on highly refined mineral oils. High degree of machine tool lubrication. Ideal for a wide range of machining operations. Low odour. Low unit cost. Specially formulated for use in both hard and soft waters.

**Recommended concentrations:**

General machining 7% (dilution of 14 to 1).  
Grinding (surface, cylindrical centreless) 2 - 3% (dilution of 50 to 1 or 33 to 1).

**NEW**



Grade	Size	Order Code
SC-GP	20ltr	<b>-4508B</b>

**Soluble Cutting Oil - Stainless**

**So-Cool 'Plus' Stainless Steel**

Environmentally improved - does NOT contain phenols, boron, triazene, PTBBA or chlorinated additives. Based on highly refined mineral oils. High degree of machine tool lubrication. Ideal for a wide range of machining operations. Low odour. Low unit cost. Stable emulsions in very soft and very hard water.

**Recommended concentrations:**

General machining 7% (dilution of 14 to 1).  
Heavy machining 10% (dilution of 10 to 1).

**NEW**



Grade	Size	Order Code
SC-INOX	20ltr	<b>-4600B</b>

**Soluble Grinding Oil - Synthetic**

**So-Cool 'Plus' Syn Grinding**

Fully synthetic formulation. Long working life therefore economical. Minimises wheel glazing. Effective corrosion resistance. Stable emulsions in soft and hard water. Does not contain PTBBA.

**Recommended concentration for general machining operations:**

Grinding cast iron 2% to 3.5% (dilution of 50 to 1 or 30 - 1).  
Steel and Ni/Cr steel 2% (dilution of 50 - 1).

**NEW**



Grade	Size	Order Code
SC-GS	20ltr	<b>-4620B</b>

**SOLENT LUBRICANTS Water Mixer**

Water and chemical mixing equipment system that is approved for use by the water regulation authority (WRA) to prevent the possibility of back flow. This is to safeguard against the possibility of chemicals finding their way into the mains water supply. Mixes water and chemicals to metered concentrations with approved air gap back flow prevention incorporated into the unit. Offers an economical way of blending chemicals directly from the mains water system without the requirement for any additional pipe-work, non-return valves or back flow prevention systems.



Product Number	Order Code
SM9100	<b>SOL-740</b> <b>-9100K</b>

**Sump Emptier**

With stainless steel Venturi pump. Screws into 205 litre oil drums. Uses compressed air to create a powerful vacuum. Empties liquid and suspended solids from tanks and can fill a drum in as little as 90 seconds, making it ready for appropriate disposal. Shuts off automatic when done.



Product Number	Order Code
PM175K	<b>SOL-740</b> <b>-8940G</b>

**Universal De-watering Fluid**

Grade SP-DWF  
Used for the drying of metal parts and tools. Resistance to acid and alkaline migration makes this suitable following galvanic coating and washing processing e.g. gear boxes, motors and their components. Ideally used in immersion baths at room temperature but is also suited to spraying. Excellent dewatering. No film. Barium-free. 20ltr stacking poly container.



Grade	Size	Order Code
SP-DWF	20ltr	<b>SOL-740</b> <b>-4270B</b>

**Tramp Oil Belt Skimmers**

Designed to effectively and simply remove tramp oil floating on the surface of cutting fluid. Prevents the 'Monday morning smell', extends coolant life and reduces the risk of dermatitis. Compact units fit to the side or above the tank. 240V. Supplied with plug. Product FT400 can be run continuously.

**Overall length:** 440mm (from top of bracket to bottom of belt).  
**Maximum insertion depth:** 150mm.  
**Case dimension (L x W x D):** 80 x 80 x 502mm.  
**Belt width:** FT300 = 30mm; FT400 = 40mm.

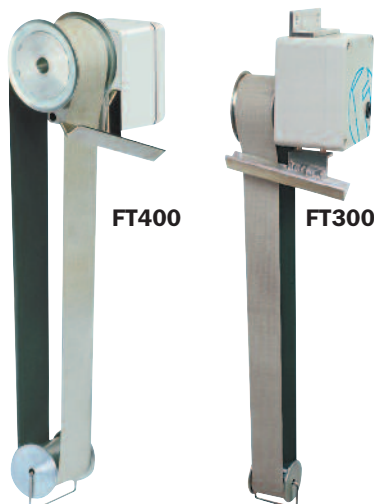

Product Number	Removal Rate	Order Code	
FT300	3ltrs per hr	<b>SOL-740</b> <b>-8860B</b>	<b>N/A</b>
FT400	4ltrs per hr	<b>-8880D</b>	

**OXFORD PRECISION Portable Optical Refractometer**

For determining the concentration of oil in water emulsions and transparent solutions, such as machine shop coolant. Maintaining the correct mixture in coolant systems is vital to ensure optimum performance from cutting tools. To protect the machine and workpiece from corrosion and to reduce the risk of health hazards arising from incorrect concentrations of water soluble oils. To economise the use of water base cutting fluids and grinding fluids.

**Range ND:** 1.333 - 1.356. Bx: 0 - 15%.  
**Eye-piece magnification:** 11x.  
**Telescopic lens magnification:** 4x.  
**Accuracy:** ±0.0003 ±0.2%  
**Latic value:** 0.0005 0.2%

Supplied in high quality fitted metal case complete with calibration screwdriver and operator manual.



**Lens for Portable Refractometer**

**Refractometer**

Dimensions	Weight each	Order Code
38 x 38 x 185mm	30g	<b>OXD-336</b> <b>-1010K</b>

**Spares**

Description	Weight each	Order Code
Lens for Portable Refractometer	10g	<b>OXD-398</b> <b>-3630K</b>

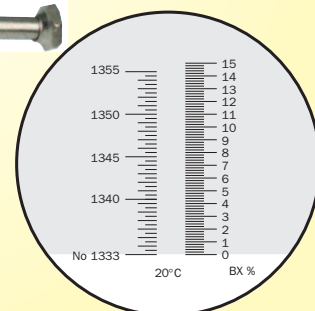

**Calibrated Refractive Scale**

**GROUP 780 FOOD SAFE OILS & GREASES**

**SOLENT FOR FOOD HYGIENE** **Food Safe Hydraulic Oil**

Designed for use in areas where incidental contact may occur, these oils are based on high quality synthetic grade oils, compounded with state of the art anti-corrosion and EP substances. Non-toxic, they comply with **FDA regulations** and are **INS H1 registered**.



**NEW**

Grade	Size	Order Code <b>SOL-740</b>
G32	20ltr	<b>-6160A</b>
G46	20ltr	<b>-6170B</b>
G68	20ltr	<b>-6180C</b>
G100	20ltr	<b>-6190D</b>

**Food Safe Clear Gear Oil**

These gear oils are made from synthetic base oils combined with selected additives to produce a high performance gear lubricant. With excellent corrosion protection, oxidation and thermal stability they extend gear life/operating duty and lower maintenance costs. **H1 registered**.



**NEW**

Grade	Size	Order Code <b>SOL-740</b>
G150	20ltr	<b>-6300A</b>
G220	20ltr	<b>-6310B</b>
G360	20ltr	<b>-6320C</b>
G460	20ltr	<b>-6330D</b>

**Food Safe Comp Tech Oil**

These compressor oils are fully synthetic, comply with **FDA regulations** and are **H1 registered**. Designed for use in food production and pharmaceutical industries they have a low friction coefficient reducing wear and energy consumption. They reduce residue, varnish and scum build up which leads to lower maintenance costs, downtime and loss of productivity.



**NEW**

Grade	Size	Order Code <b>SOL-740</b>
G46	20ltr	<b>-6370A</b>
G68	20ltr	<b>-6380B</b>
G100	20ltr	<b>-6390C</b>

**Synthetic Grease**

Constructed using pure non-toxic synthetic base oils, combined with PTFE and a complex mix of anti-oxidant and EP packages. Completely resistant to salt water and high humidity environments. Dielectric and can be used to protect electrical equipment from ingress of water. Lubricates bearings, chains and sliding surfaces including plastic bearings and runners. Has a wide temperature operating range -40°C to 340°C. Grease clean food safe lubricant. Non-melting.



Size	Order Code <b>SOL-740</b>
100ml	<b>-6200A</b>
400ml	<b>-6210B</b>
5.0kg	<b>-6215E</b>
12.5kg	<b>-6217H</b>

**Food Safe Silicone Grease**

A versatile silicone grease for operation in extremes of high and low temperature. Can also be used on food product applications or where water repellent properties are of prime importance as it offers excellent physical performance and is **INS H1 registered**. Non-melting, water repellent, odourless, non-toxic, low volatility. High dielectric. resistant to oxidation. Thermally stable ozone resistant. Minimal effects on rubbers, plastics and metals. Unaltered by UV light.



Size	Order Code <b>SOL-740</b>
100ml	<b>-6250D</b>
400ml	<b>-6260E</b>
500g	<b>-6270F</b>
5.0kg	<b>-6280G</b>
12.5kg	<b>-6290H</b>

**Food Safe White Grease**

Intended use for lubrication of bearings, slides and all delicate mechanisms used in the food manufacturing/processing industry. Maximum operating temperature 150°C with excellent load carrying capacity and water resistance. **FDA Compliant**. **INS H1 registered**. Non-toxic.



Size	Order Code <b>SOL-740</b>
400ml	<b>-5900A</b>
5.0kg	<b>-5905C</b>
12.5kg	<b>-5910E</b>

**Food Safe Anti-Seize Paste**

Formulated for use on assemblies in difficult areas where fretting corrosion and corrosion induced by wet environments occur. It can also be used to lubricate slow moving slides and pivot pins. Resistant to hot, cold and salt water it can be used across a wide temperature range where the solid lubricate including PTFE gives excellent dry lubrication and forms a barrier between all surfaces. Non-toxic, it complies with FDA regulations and is H1 registered.



**NEW**

Grade	Size	Order Code <b>SOL-740</b>
FSASP	500g	<b>-6720B</b>

**LUBRICANTS & CHEMICAL PRODUCTS**



**Food Safe Penetrating Oil**

For dismantling, lubricating and cleaning. This odourless oil is tasteless and displaces water leaving a hydrophobic coating to protect surfaces from corrosion. It penetrates threads and crevices to release and lubricate delicate mechanisms, pivot points and sliding surfaces whilst degreasing hard surfaces. Can be used as a light lubricant. **FDA Compliant. INS H1 registered.** Food safe. Synthetic translucent. Tasteless water white fluid. Non-toxic. Anti-corrosive.



Size	Order Code
500ml	<b>SOL-740</b> <b>-5930D</b>

**Food Safe Lubricating Oil**

This lubricant is completely clear, odourless and food safe, it contains no mineral hydrocarbons and meets with **FDA** and is **INS H1 registered**. It is a hydrophobic oil and therefore does not take in water, providing a barrier between water condensation and metal surfaces. This versatile lubricant can be used on sliding and rolling element bearing surfaces, metal, wood and plastics. Non-flammable. Non-toxic. Anti-corrosive. Safe for use at temperatures from -60° to +260°C.



Size	Order Code
500ml	<b>SOL-740</b> <b>-5960G</b>
5ltr	<b>-5970H</b>

**Food Safe High Tech Grease**

Food safe synthetic PTFE grease is a fully synthetic translucent non-melting grease that allows fluid to penetrate into machine parts before setting to a No. 2 rated grease. Protects and lubricates with a non-toxic anti-corrosive shield for use on sliding and rolling element bearing surfaces, metal, wood and plastics. Non-toxic lubricant ingredients listed by the **FDA** and is **INS H1 registered**. Totally salt or fresh water-resistant to be used inside and out on machinery in temperatures ranging from -40°C to +340°C.



Size	Order Code
500ml	<b>SOL-740</b> <b>-6220C</b>

**Food Safe Belt Tech**

This **H1 registered** product is designed to extend life of leather, rubber and sythetic belts. Cleanly applied from the 500ml aerosol, it improves grip and allows the belt to transmit full power without slipping even in wet and damp environments.



**NEW**

Size	Order Code
500ml	<b>SOL-740</b> <b>-6760F</b>

**Food Safe White Grease**

Intended use for lubrication of bearings, slides and all delicate mechanisms used in the food manufacturing/ processing industry. Maximum operating temperature 150°C with excellent load carrying capacity and water resistance. Non-toxic. **FDA Compliant. NSF H1 registered.**



**NEW**



Size	Order Code
500ml	<b>SOL-740</b> <b>-6850E</b>

**Food Safe Degreaser**

This **H1 registered** all-purpose cleaner/ degreaser is designed for food production areas where incidental contact may occur. It is non-abrasive, non-chlorinated, water clear, low odour, fast evaporating, it leaves no residue or deposits behind. It can be safely used on machinery, worktops and floors.



**NEW**



Size	Order Code
500ml	<b>SOL-740</b> <b>-6810L</b>

**LUBRICANTS & CHEMICAL PRODUCTS**

**SOLENT™ SPILL CONTROL** **2-Drum Spill Pallet**

100% polyethylene construction is resistant to corrosion and the knocks and scrapes of the industrial environment. Fully compliant with all current regulations.



Product Number	Dimensions (cm)	Sump (ltrs)	Order Code
SDP-2	122 x 82 x 33	240	<b>-5110A</b>

**4-Drum Spill Pallet**

Compact 4-drum pallet with a low loading height of only 28cm. The sump capacity of 230ltr is large enough to comply with the regulations. 100% polyethylene construction.



Product Number	Dimensions (cm)	Sump (ltrs)	Order Code
SDP-4	128 x 128 x 28	230	<b>-5120A</b>

**4-Drum In-Line Spill Pallet**

Use this spill pallet where space is at a premium. The unique design allows for the drums to be stored length wise along a wall while still complying with the regulations. Tough 100% polyethylene construction.



Product Number	Dimensions (cm)	Sump (ltrs)	Order Code
SDP-4L	249 x 64 x 30	250	<b>-5120L</b>

**2-Drum Workfloor**

Workfloors are a viable alternative to spill pallets where a lower working height is required for easier access. A bundled storage and dispensing area can easily be created by making use of a selection of the three different sizes. All polyethylene construction. All three models of workfloor, SW-2, SW-4 (right) and SW-4IL (next page) have the same 15cm height for easier loading and unloading.

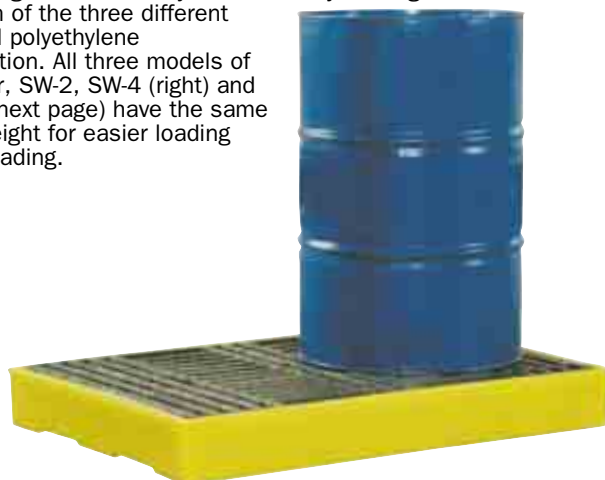

Product Number	Dimensions (cm)	Sump (ltrs)	Order Code
SW-2	126 x 86 x 15	150	<b>-6410A</b>

**Drum Trolley**

This easy to use unit combines safe transport, storage and dispensing from drums all in one. Any spills that occur during dispensing are safely stored in the sump. Simple to use one person operation.



Product Number	Dimensions (cm)	Sump (ltrs)	Order Code
SDT-230	160 x 74 x 64	230	<b>-5500T</b>

**4-Drum Workfloor**

All three models of workfloor, SW-2 (left), SW-4 and SW-4IL (next page) have the same 15cm height for easier loading and unloading. The grates are easily removed for cleaning.



Product Number	Dimensions (cm)	Sump (ltrs)	Order Code
SW-4	166 x 126 x 15	300	<b>-6420B</b>

**SOLENT™ SPILL CONTROL™ 4-Drum In-Line Workflow**

All three models of workflow, SW-4IL, SW-2 and SW-4 (both previous page) have the same 15cm height for easier loading and unloading. The grates are easily removed for cleaning.



Product Number	Dimensions (cm)	Sump (ltr)	Order Code
SW-4IL	260 x 90 x 15	300	<b>SOL-741</b> <b>-6421C</b>

**Workflow Ramp**

This ramp is designed to be safe to use with any size of workflow, with an integral joining strip to ensure that it stays in position and a ribbed surface for better grip. At only 80cm wide it can be fitted to any edge of each of the work floors. 100% polyethylene.



Product Number	Dimensions (cm)	Sump (ltr)	Order Code
SWR-1	65 x 80 x 16	-	<b>SOL-741</b> <b>-6520R</b>

**Bench Tray**

For use in a laboratory or other areas where small containers are in use and it is essential that any spills are contained. Removable grate for easy cleaning.



Product Number	Dimensions (cm)	Sump (ltr)	Order Code
SW-T1	63 x 55 x 7	9.5	<b>SOL-741</b> <b>-6530T</b>

**Drum Funnel**

An essential item when filling either a drum or IBC, particularly with waste fluids. Designed to ensure that there are no spills with an integral lid so that the funnel can be left in place when not in use. Fits over the top of a 205ltr drum. Does not rust or corrode.



Product Number	Dimensions (cm)	Sump (ltr)	Order Code
SF-20L	61 dia x 23	250	<b>SOL-741</b> <b>-5650X</b>

**Small Container Trays**

Small drums are just as likely to leak or spill as large ones. These three different sizes cope with drums up to 25ltr. 100% polyethylene resists corrosion.



**SWB1**



**SWB2**



**SWB4**

Product Number	Dimensions (cm)	Sump (ltr)	Order Code
SWB1	55 x 55 x 11	27.5	<b>SOL-741</b> <b>-6810A</b>
SWB2	72 x 46 x 11	27.5	<b>-6820B</b>
SWB4	92 X 72 x 18	100	<b>-6840D</b>

**Circular Drum Tray**

Where there is only one drum in use in an area, the Oil Storage Regulations state that a drum tray with a capacity that is 25% of the size of the drum is sufficient. This 100% polyethylene circular tray meets the requirement. It is also ideal as a temporary bund for smaller items during maintenance operations, including batteries.

**Drum not included**



Product Number	Dimensions (cm)	Sump (ltr)	Order Code
SOT-8	87 dia x 19	50	<b>SOL-741</b> <b>-5840T</b>

**SOLENT™ SPILL CONTROL** **Single IBC  
Spill Pallet**

This unique design is complete with a bucket space for the splash-proof dispensing of fluids from the IBC. Any type of IBC with an integral pallet can be used.

**NEW**



Product Number	Dimensions (cm)	Sump (ltr)	Order Code
SSP110	140 x 195 x 73	1100	<b>SOL-741</b> <b>-6240S</b>

**Drain Covers**

When a spill occurs outside, the most likely outlet for fluids to run away to are the drains. It is a legislative requirement that sufficient protection is in place for all at-risk drains. This is best met with one or more drain covers, of which three types are available. The clay drain covers are only for use in an emergency, as once moulded to the drain they cannot be reused. Where ongoing use is anticipated, such as each time a bulk delivery is made, a polyurethane cover should be used. The neoprene cover (not illustrated) is for occasional use only.



Product Number	Dimensions (cm)	Sump (ltr)	Order Code
SDC614	65 x 45 Clay	2	<b>-3020C</b>
SDC101N	100 x 100 Neoprene	1	<b>-3000A</b>
SDC616P	61 x 61 Polyurethane	1	<b>-3030D</b>

**Audit Spill Kit Covers**

Spill kit audit covers are yellow, weatherproof PVC covers with elasticated cord to allow fitting over the top of a 2-wheeled wheelie bin spill kit. A4 sized clear pouch for inserting audit record sheet. Tamperproof tape fitted on the container and cover indicates whether any of the contents have been used. Depleted spill kits are classified as **ISO14001 non-conformity**. Available in sizes to fit wheelie bins of capacities: 120 and 240ltr.



Product Number	To Fit 2 Wheeled Bin Size	Order Code
AVC 120	120ltr	<b>SOL-742</b> <b>-5440V</b>

**Drum Plug**

Ideal for rapid response to unexpected releases of liquid. Provides temporary plugging of holes in drums or pipes. Pre-mixed putty is ready to use. No surface preparation is required. Applies directly onto container to form a seal. Bentonite clay granules that form a barrier to aqueous liquids. Non-toxic.



Tub Size	Order Code
1kg	<b>SOL-741</b> <b>-2880R</b>

**Clay Absorbent Granules**

These traditional absorbent clay granules absorb oil, water and most other fluids. Non-toxic, chemically inert. 20ltr.

**NEW**



Bag Size	Order Code
20ltr	<b>SOL-742</b> <b>-8250A</b>



**SOLENT+<sup>PLUS</sup>** **Spill Response Kits**

There are many situations where there is a need for a permanent supply of absorbents to be on hand. Solent Plus™ spill kits are a cost-effective answer to this requirement. Available in Maintenance, Oil-only and Chemical kits, they range in capacity from 10ltr up to 240ltr. They are packed with sufficient absorbents to cope with a spill up to the size shown.

**Clip-Closed Carrier Spill Kits**

**Contents**

**15ltr**  
10x pads, 1x sock, 1x gloves, 1x disposal bag.

**NEW**

**15ltr Clip Closed Carrier Spill Kits**



Product Number	Format	Absorbs (ltr)	Order Code SOL-742
PMK015B	Maintenance, Clip Closed Carrier	15	<b>-6130M</b>
POK015B	Oil only, Clip Closed Carrier	15	<b>-6135N</b>
PCK015B	Chemical, Clip Closed Carrier	15	<b>-6140P</b>

**Vinyl Holdall Spill Kits**

**Contents**

**10ltr**  
10x pads, 1x sock, 1x gloves, 1x 1kg tub drum plug, 2x disposal bags.

**10ltr Vinyl Holdall Spill Kits**



**20ltr**  
15x pads, 2x socks, 1x gloves, 3x disposal bags.

**20ltr Vinyl Holdall Spill Kits**



**50ltr**  
35x pads, 3x socks, 3 x pillows, 1x gloves, 5x disposal bags.

**50ltr Vinyl Holdall Spill Kits**

Product Number	Format	Absorbs (ltr)	Order Code SOL-742
PMK010B	Maintenance, Vinyl Holdall, Velcro Closure	10	<b>-6100A</b>
POK010B	Oil only, Vinyl Holdall, Velcro Closure	10	<b>-6110B</b>
PCK010B	Chemical, Vinyl Holdall, Velcro Closure	10	<b>-6120C</b>
PMK020C	Maintenance, Vinyl Holdall, Zip Closure	20	<b>-6150D</b>
POK020C	Oil only, Vinyl Holdall, Zip Closure	20	<b>-6160E</b>
PCK020C	Chemical, Vinyl Holdall, Zip Closure	20	<b>-6170F</b>
PMK050S	Maintenance, Vinyl Holdall, Velcro Closure	50	<b>-6200G</b>
POK050S	Oil only, Vinyl Holdall, Velcro Closure	50	<b>-6210H</b>
PCK050S	Chemical, Vinyl Holdall, Velcro Closure	50	<b>-6220J</b>

**Small Poly Bin Spill Kits**

**Contents**

**25ltr**  
17x pads, 1x sock, 2x pillows, 1x gloves, 4x disposal bags.

**25ltr Small Poly Bin Spill Kits**



Product Number	Format	Absorbs (ltr)	Order Code SOL-742
PMK025A	Maintenance, Small Poly Bin	25	<b>-6300A</b>
POK025A	Oil only, Small Poly Bin	25	<b>-6310B</b>
PCK025A	Chemical, Small Poly Bin	25	<b>-6320C</b>

**2-Wheeled Poly Bin Spill Kits**

**Contents**

**120ltr**  
75x pads, 9x socks, 8x pillows, 1x goggles, 1x gloves, 1x coverall suit, 10x disposal bags.

**240ltr**  
200x pads, 12x socks, 10x pillows, 1x goggles, 1x gloves, 1x coverall suit, 18x disposal bags.

**120ltr & 240ltr 2-Wheeled Poly Bin Spill Kits**



Product Number	Format	Absorbs (ltr)	Order Code SOL-742
PMK120B	Maintenance, 2-Wheeled Poly Bin	120	<b>-6350D</b>
POK120B	Oil only, 2-Wheeled Poly Bin	120	<b>-6360E</b>
PCK120B	Chemical, 2-Wheeled Poly Bin	120	<b>-6370F</b>
PMK240B	Maintenance, 2-Wheeled Poly Bin	240	<b>-6400G</b>
POK240B	Oil only, 2-Wheeled Poly Bin	240	<b>-6410H</b>
PCK240B	Chemical, 2-Wheeled Poly Bin	240	<b>-6420J</b>

**LUBRICANTS & CHEMICAL PRODUCTS**



**'Natural' Absorbents from Sustainable Resources**

Rather than relying on a non-renewable resource such as polypropylene for their construction, this all new range of absorbent pads, rolls and socks from Solent Plus™ utilises raw materials that are constituted 80% cellulose fibre in their manufacture. Cellulose fibres are one of the most widely available sustainable resources and have a low dependence on fossil fuels. All of the products are available in either maintenance or oil-only grades, and represent a viable, cost-effective alternative to traditional melt-blown absorbents. The performance is equal to, if not better in some cases than conventional absorbents. Of particular note here is the oil pad, which has a class-beating absorbency rating of up to 1.4ltr per pad.

**'Natural' Pads**

**NEW**

**PACK OF 100**



Dimensions (cm x cm)	Format	Pack Quantity	Absorbs (ltr)	Order Code SOL-742
48 x 38	Maintenance	100	0.8	<b>-4510K</b>
48 x 38	Oil only	100	1.4	<b>-4550P</b>

**'Natural' Socks**

**NEW**

**PACK OF 20**



Dimensions (cm x m)	Format	Pack Quantity	Absorbs (ltr)	Order Code SOL-742
7.5 x 1.2	Maintenance	20	4.0	<b>-4530M</b>
7.5 x 1.2	Oil only	20	4.0	<b>-4570R</b>

**'Natural' Rolls**

**NEW**



Dimensions (cm x m)	Format	Pack Quantity	Absorbs (ltr)	Order Code SOL-742
37 x 38	Maintenance	1	62.0	<b>-4520L</b>

**Absorbent Socks**



Make use of socks where liquids need to be contained. Particularly useful for putting round the base of machinery and in food stores around the base of freezers (use the maintenance grade). Colour-coded for ease of selection. Oil-only socks repel water and only absorb oil and fuels.



Product Number	Dimensions (cm x m)	Format	Pack Quantity	Absorbs (ltr)	Order Code SOL-742
SMS810	7.5 x 1.0	Maintenance	50	3.7	<b>-2960M</b>
PMS812	7.5 x 1.2		20	4.5	<b>-4170N</b>
PMS830	7.5 x 3.0		8	11.2	<b>-4180P</b>
75-3056	7.5 x 1.2	Oil only	20	4.0	<b>-4470X</b>
POS830	7.5 x 3.0		8	10.0	<b>-4480Z</b>
PCS812	7.5 x 1.2	Chemical	20	4.0	<b>-4770H</b>
PCS830	7.5 x 3.0		8	10.0	<b>-4780K</b>

**Absorbent Booms**

Use to contain oil or fuel spills on water. The fill is hydrophobic, which means that they repel water while absorbing oils and fuels. Will stay afloat on water even when saturated with oil. Use the clips and rings to join more than one boom together for larger spills. Convenient 3m length for ease of handling.



**PACK OF 4**

Product Number	Dimensions (cm x m)	Format	Pack Quantity	Absorbs (ltr)	Order Code SOL-742
SB0123	13 x 3	Oil only	4	29.5	<b>-0820J</b>
SB0203	20 x 3	Oil only	4	79.0	<b>-0840L</b>

**Absorbent Pillows**

These absorbent pillows are particularly useful for coping with persistent leaks that require more than the absorbent capacity offered by pads. Can be left in place under machinery.



**PACK OF 16**

Product Number	Dimensions (cm x cm)	Format	Pack Quantity	Absorbs (ltr)	Order Code SOL-742
SMC303	38 x 23	Maintenance	16	4.0	<b>-2610F</b>
SOC303	38 x 23	Oil only	16	3.5	<b>-2620G</b>

**LUBRICANTS & CHEMICAL PRODUCTS**



**SOLENT PLUS** **Absorbent Pads**

Solent Plus™ absorbent pads are available in two thicknesses, medium or light and are suitable for use anywhere that fluids have leaked or spilt. Simple colour coding makes selection easy. For most indoor applications use grey/black. These will absorb most fluids, including oils, fuels, solvents, coolants, water and foodstuffs such as milk or wine. If there's a possibility of aggressive fluids such as acids or alkalis being spilt, use the yellow ones. Where an oil or fuel spill is likely outdoors, it's best to put the white ones in place. These repel water while absorbing the oils and fuels.



**Maintenance Absorbent Pads**

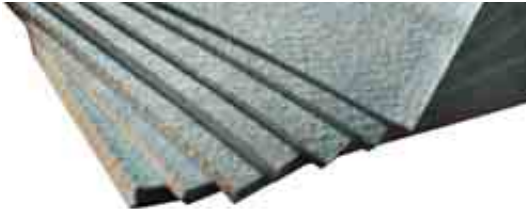

Product Number	Dimensions (cm x cm)	Format	Pack Quantity	Absorbs (ltr)	Order Code SOL-742
PMP503	50 x 40	Maint./Med	100	0.80	-4010J
SMP504	50 x 40	Maint./Light	200	0.50	-2860K
SMP501	50 x 40	Maint./Light	50	0.50	-2850J

**Oil Only Absorbent Pads**



Product Number	Dimensions (cm x cm)	Format	Pack Quantity	Absorbs (ltr)	Order Code SOL-742
POP100	50 x 40	Oil only/Med	100	0.80	-4310R
SOP200	50 x 40	Oil only/Light	200	0.65	-3360S
SOP501	50 x 40	Oil only/Light	50	0.65	-3420H

**Chemical Only Absorbent Pads**

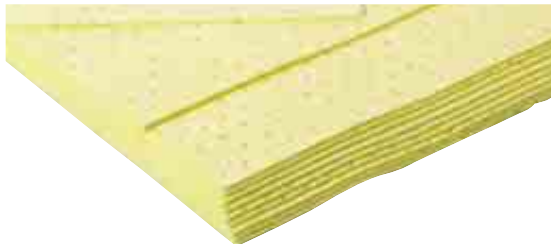

Product Number	Dimensions (cm x cm)	Format	Pack Quantity	Absorbs (ltr)	Order Code SOL-742
PCP504	50 x 40	Chemical/Med	100	0.80	-4610A

**Absorbent Drum Top Covers**

Cut to fit exactly on the top of a 205ltr drum, these covers help keep a dispensing area free of leaks and drips. Each cover will absorb up to 1ltr of most industrial fluids.

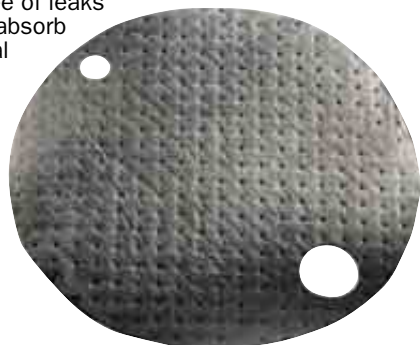

**PACK OF 5**

Product Number	Dimensions Diameter	Format	Pack Quantity	Absorbs (ltr)	Order Code SOL-742
MPA5656	56cm	Maintenance	5	1.0	-0620B

**Absorbent Rolls**

Many applications for absorbents can be met by making use of one or more of these rolls. Make a selection from medium weight 50cm or 90cm wide, or lightweight 50cm x 40m long. All sizes and weights are perforated for economy of use.



Product Number	Dimensions (cm x m)	Format	Pack Quantity	Absorbs (ltr)	Order Code SOL-742
PMR505	50 x 40	Maint./Med	1	80	-4100C
PMR905	90 x 40	Maint./Med	1	144	-4110L

Product Number	Dimensions (cm x m)	Format	Pack Quantity	Absorbs (ltr)	Order Code SOL-742
POR130	50 x 40	Oil only/Med	1	80	-4400T
POR260	90 x 40	Oil only/Med	1	144	-4410V

Product Number	Dimensions (cm x m)	Format	Pack Quantity	Absorbs (ltr)	Order Code SOL-742
PCR484	50 x 40	Chemical/Med	1	80	-4700C
PCR905	90 x 40	Chemical/Med	1	144	-4710D

**Cube Bag Spill Kits**

Contain a range of absorbent products and disposal bags for dealing effectively and quickly with spills.

**Contents**

**35ltr**

1x printed cube bag, 2x socks (80mm x 3m), 15x pads (double weight), 1x disposal bag and tie, 1x instruction sheet.



Product Number	Format	Absorbs (ltr)	Order Code SOL-742
SMK35Y	Maintenance, Vinyl Holdall, Zip Closure	35	-5150S
SOK35Y	Oil only, Vinyl Holdall, Zip Closure	35	-5160T
SCO35Y	Chemical, Vinyl Holdall, Zip Closure	35	-5170V

**LUBRICANTS & CHEMICAL PRODUCTS**

**SOLENT** Professional Hand & Skin Care System  
CLEANING & HYGIENE

The Solent™ Cleaning and Hygiene pouch hand cleanser/soap system uses 2ltr sealed pouch cartridges to minimise spillages and waste, this system helps to prevent cross contamination. A full range of barrier creams, sanitisers, soaps, beaded hand cleansers and afterwork reconditioning creams are available for use with the dispensers.

**Dispenser Pumps**

**All creams, soaps and gels:**  
Use with 2mm pump.

**All beaded hand cleansers:**  
Use with 3mm pump.

**CUT OUT CROSS CONTAMINATION!**



Pump Size	Capacity	Use With	Order Code
			<b>SOL-780</b>
2mm	2ltr	Creams Soap & Gels	<b>-1160J</b>
3mm	2ltr	Beaded Cleaners	<b>-1150H</b>

**PROTECT**

**Universal Barrier Cream**

A pre-work cream that protects your hands. Use with 2mm pump dispenser. Supplied individually, boxed in 6s.



Description	Pouch Size	Order Code
Universal Barrier Cream	2ltr	<b>-1950Q</b>

**SANITISE**

**Anti-Bacterial Cleansers**

**Anti-Bacterial Soap**

Formulated from a blend of natural soap, conditioner and mild surfactants. Ideal for frequent use. Supplied individually, boxed in 6s.

**Cool Gel Hand Sanitiser**

An alcohol-based hand sanitiser kills any bacteria (effective against MRSA) yeast or moulds. Use with 2mm pump dispenser. Supplied individually, boxed in 6s.



Description	Pouch Size	Order Code	
Anti Bacterial Soap	2ltr	<b>-2560F</b>	N/A
Cool Gel Sanitiser	2ltr	<b>-2660J</b>	N/A

**RESTORE**

**Afterwork Reconditioning Hand Cream**

Replaces natural oils removed during a days work. Use with 2mm pump dispenser. Supplied individually, boxed in 6s.



Description	Pouch Size	Order Code
Afterwork Cream	2ltr	<b>-1980T</b>

**CLEANSE**

**Beaded Hand Cleaners**

Citrus-based beaded hand cleaners. Use with 3mm pump dispenser. Supplied individually, boxed in 6s.



Description	Pouch Size	Order Code	
Lemon Hand Cleaner	2ltr	<b>-0901F</b>	N/A
Lime Hand Cleaner	2ltr	<b>-1001F</b>	N/A
GT Hand Cleaner	2ltr	<b>-2550E</b>	N/A

**Luxury Soaps**

**Luxury Peach Soap**

Luxury peach soap produces a rich creamy lather for effective hand cleaning. Lightly scented with a fresh peach fragrance. Use with 2mm pump dispenser. Supplied individually, boxed in 6s.

**Gel Soap**

Pure golden, unperfumed gel soap suitable for all general hand cleaning uses. Use with 2mm pump dispenser. Supplied individually, boxed in 6s.



Description	Pouch Size	Order Code	
Peach Luxury Soap	2ltr	<b>-2630A</b>	N/A
Gel Soap	2ltr	<b>-2680L</b>	N/A

**Blue Ocean Hair & Body Shampoo**

A mild non-alkaline, neutral formulation suitable and safe for use in the work place and leisure centres. Use with 2mm pump dispenser. Supplied individually, boxed in 6s.



Description	Pouch Size	Order Code	
Blue Ocean Shampoo	2ltr	<b>-0820R</b>	N/A



**SOLENT** *CLEANING & HYGIENE* **Beaded Hand Gel Cleanser - Lime**

Heavy-duty citrus-based degreasing and cleansing agent. Hard on grime yet kind to your skin. Unique lemon and lime formula combines nature's strength and fragrance. Ideally suited for industrial, household, workshop, outdoor, cleaning of hands. Now available in four sizes with suitable dispensing equipment.



**ENVIRONMENTALLY FRIENDLY FORMULATION**

Description	Size	Order Code SOL-780
Cartridge	2ltr	-1002G
Tub	3ltr	-1003H
Poly-bottle	5ltr	-1005L
Pail	15ltr	-1015M
Pump dispenser for 5ltr poly-bottle		-1125D
Pump dispenser for 3ltr Tub		-1130F
Cage only for 3ltr tub		-2300W



Description	Order Code SOL-780
Tub Kit (1x Tub, 1x Cage, 1x Pump)	-1140G

**Orange D440 Beaded Hand Cleaner**

Non-toxic, citrus-based beaded hand cleaner, cuts through the heaviest of industrial grease and grime quickly and easily. Environmentally friendly, and contains no harsh chemicals. Removes oil, tar, grease, paint, ink, glue etc. Antiseptic and bactericidal. Water rinsable, leaves no oily residue.



Size	Order Code SOL-780	
2.5ltr	-1202G	N/A

**Swarf Beater Hand Gel**

Lime green coloured unperfumed gel soap. Easy to apply and quickly rinses off with water leaving no residue on the skin. Suitable for removing oil, grease, and general soiling. Handy 240g tub size for easy carrying and storage.



Size	Order Code SOL-780	
240g	-2540D	N/A

**Lemon™ Beaded Hand Cleaner**

Naturally powerful citrus-based beaded hand cleaner. Contains thousands of poly beads that produce a micro-pumice cleaning action that easily removes stubborn grime, without damaging the skin. Combined with a citrus-based degreaser, that is environmentally friendly, and contains no harsh chemicals. Removes oil, tar, grease, paint, ink, glue etc. A deodorising lemon scent that eliminates oil and swarf odours, leaving the skin feeling fresh after use. Water rinsable - leaves no oily residue.

**Natural Beaded Hand Cleaner**

Natural beaded hand cleaner uses two types of scrubbing additives, wood flour to absorb grease/grime and poly beads to remove more stubborn soiling like tar, inks and paints. These combine to produce a dense cleansing lather to deliver a powerful solvent-free natural cleaning action that is gentle on your skin.



Description	Size	Order Code SOL-780
Poly Bottle	5ltr	-1305L
Pail	15ltr	-1315M



Type	Size	Order Code SOL-780
Poly Bottle	5ltr	-0855L
Pail	15ltr	-0865M

**Liquid Hand Soap - Professional**

Luxury peach soap leaves hands feeling clean, smooth and conditioned.



Type	Order Code SOL-780	
1ltr	-2600X	N/A
5ltr	-2610Y	N/A

**Professional Hand Soap**

Supplied in packs of 12x 70g bars. Lightly scented. Suitable for domestic use, in hotels, schools, restaurants and any commercial premises. Produces a rich creamy lather in all water types.



Type	Pack Qty	Weight/pack	Order Code SOL-780
Buttermilk	12	840g	-2530D

LUBRICANTS & CHEMICAL PRODUCTS

**GROUP 780 HAND & SKIN CARE**

**SOLENT CLEANING & HYGIENE Dry Work Barrier Cream**

Pre-work cream protects skin against dry substances, dry powders, oils or solvent-based liquids.



Size	Order Code
2.5kg	<b>SOL-780 -2020B</b>

**Wet Work Barrier Cream**

Pre-work cream protects skin against water-based liquid solutions, cutting oils, detergents, acids, coolants and foodstuffs.



Size	Order Code
1ltr	<b>SOL-780 -2050D</b>
2.5kg	<b>-2060E</b>

**Reconditioning Cream - Professional**

Replaces moisture loss after contact with contaminants, contains natural oils to keep skin moist.

**Size:** 1ltr.



Description	Order Code
Reconditioning Cream	<b>SOL-780 -2100G</b>

**Standard Duty Workshop Hand Wipes**

Soft white wipes. Removes oil, grease, ink and general dirt. Waterless - no need to rinse hands after cleaning. Ideal for mobile repair and maintenance vans and use around the workshop.



**PACK OF 150**

Product Type	Pack Qty	Order Code	Price/Pk
Standard Duty	150	<b>SOL-930 -3900K</b>	

**Heavy Duty Hand Wipes**

Impregnated with mild abrasive fibres to remove oil, grease, general grime plus difficult to remove contaminants such as paints, sealants, most inks and ground-in dirt. A genuine waterless hand cleaning wipe with no need to rinse after use, ideal for mobile repair and maintenance vans as well as use around the workshop. Supplied in handy pack of 50 wipes or tubs of 100 wipes.



Product Type	Pack Qty	Order Code	Price/Pk
Handy Pack	50	<b>SOL-930 -3800K</b>	
Tub	100	<b>-4000K</b>	

**SOLENT HYGIENE FOR FOOD Food Safe Wipes**

**Hand Wipes**  
These non-toxic single use wipes are excellent for killing lethal bacteria and prevent cross-contamination.

**Size:** 20 x 30cm.



**PACK OF 200**

Description	Pack Qty	Order Code	Price/Pk
Hand Wipes	200	<b>SOL-930 -4400K</b>	

**Cool Gel Handy Packs**

Alcohol-based. Kills any bacteria (effective against MRSA) yeast or moulds. Fast drying removing the need for rinsing or drying with towels. Now available in two handy pack sizes for use on the move or at work.



Size	Order Code	
80ml	<b>SOL-780 -2650E</b>	N/A
500ml	<b>-2652G</b>	N/A

**Hand Cleanser**

**Anti-Bacterial Hand Soap**

Formulated from a blend of natural soap, conditioner and mild surfactants. Ideal for frequent use.



**NEW**

Description	Size	Order Code	
Anti-bacterial Hand Soap	500ml	<b>SOL-780 -2558D</b>	N/A

**Luxury Peach Soap**

Produces a rich creamy lather for effective hand cleaning. Lightly scented with a fresh peach fragrance.



**NEW**

Description	Size	Order Code	
Luxury Peach Soap	500ml	<b>SOL-780 -2598V</b>	N/A
Luxury Peach Soap	2ltr	<b>-2620Z</b>	N/A

**LUBRICANTS & CHEMICAL PRODUCTS**

**SOLENT OFFICE** **Air Duster**  
CLEANING & HYGIENE

HFC-free. Designed to remove dust and dirt from hard to reach areas. Environmentally friendly, does not contribute to global warming. Extension tube included.



400 ml

**NEW**

Order Code  
**SOL-780**

**-6800A**

**Anti-static Screen Cleaner**

Anti-static screen cleaner for use on all screens including TFT, TV and Plasma screens. No alcohol, non-toxic, non-hazardous cleaner and protector. Will reduce build-up of dust and dirt that can cause headaches and eyestrain. 250ml spray bottle.



250 ml

**NEW**

Order Code  
**SOL-780**

**-6860G**

**SOLENT MAINTENANCE** **Graffiti Remover**

An aggressive graffiti remover suitable for cleaning the following surfaces: polyethylene, polypropylene, nylon, uPVC, bare metal surfaces, powder coated surfaces, varnished wood, reflective signs and acrylics. May be used on some gloss paints (small test area first advised).

**Size: 500ml.**



**NEW**

Order Code  
**SOL-732**

**-0300K**

**Antistatic Screen Wipes**

Antistatic screen wipes. Pre-saturated for use on screens including TFT, TV and Plasma screens. Will reduce build-up of dust that can cause headaches and eyestrain. Bio-degradable. No alcohol, non-toxic, non-hazardous.



PACK OF  
**100**

**NEW**



Order Code  
**SOL-780**

**-6880J**

**Screen Wipe Hygiene Sachets**

Hygienic sachets for use on most screens. No alcohol, non-toxic, non-hazardous cleaner and protector. Will reduce build-up of dust and dirt that can cause headaches and eyestrain.



**NEW**

PACK OF  
**50**

Order Code  
**SOL-780**

**-6890K**

**Dry Absorbent Wipes**

Essential for mopping up desktop spills fast! Tough and very absorbent. Safe to use on most screens as the material has a low lint content and will not scratch. Useable with all cleaning fluids and foams.



**NEW**

PACK OF  
**50**

Order Code  
**SOL-780**

**-6840E**

**Multi-Purpose Wipes**

Antibacterial multi-purpose wipes. Effectively cleans hard surfaces, computer casing, desks, telephones etc. Anti-bacterial formulation effective against E.coli, salmonella, MRSA and influenza virus. Helps to reduce build-up of dust and dirt where germs can breed.



**NEW**

PACK OF  
**100**

Order Code  
**SOL-780**

**-6920N**

**Telephone Wipe Hygiene Sachets**

Effectively cleans telephones, headsets and any other equipment that comes into contact with ear or mouth. Non-toxic, non-hazardous cleaner. Will help to reduce the build-up of dirt and dust where germs can breed.



PACK OF  
**50**

**NEW**

Order Code  
**SOL-780**

**-6950R**

**Whiteboard Cleaner & Wipes**

**Whiteboard Cleaner**  
Cleans like new! Effectively cleans dry wipe marker pen from most whiteboards. Non-toxic, non-hazardous fluid. 250ml spray bottle. Use with Solent Dry Wipe Cloths (SOL-780-6840E) available separately.

**NEW**

**Whiteboard Wipes**

Pre-moistened whiteboard wipes effectively cleans dry wipe marker pen from most whiteboards. Non-toxic. Non-hazardous. Leaves whiteboards looking like new. Pack of 100.

250 ml



PACK OF  
**100**

Description

Order Code  
**SOL-780**

Cleaner  
Wipes - Tub 100

**-7000A**  
**-7020C**



**Contract Bleach**

A solution containing 4% sodium hypochlorite, for use in toilets, sinks and drains.



Type	Size	Order Code
Poly-bottle	5ltr	<b>-3001M</b>

**Spray & Wipe with Bleach**

Bactericidal cleaner specially formulated to remove mould/mildew stains, soap residues, grease/oils from around sinks, showers, baths and similar hard surfaces. Also acts as a highly effective sanitiser against all bacteria.



Size	Order Code
750ml	<b>-3032V</b>

**Oven Cleaner**

Removes baked-on grease and food residues from ovens and grills. Do not use on aluminium or galvanised metal. Approximate cleaning times: Light grease: 3 mins (cold oven), 1 min (hot oven). Heavy grease: 30 mins (cold), 5 mins (hot). Baked on grease: 12 hrs (cold), 2 hrs (hot).

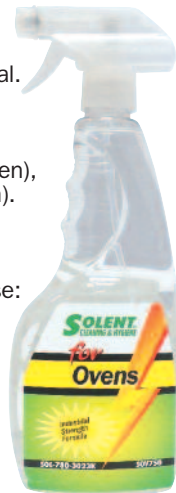

Size	Order Code
750ml	<b>-3023K</b>

**Hard Surface Cleaner**

This hard surface cleaner is great for sanitising aluminium, stainless steel, glass, plastics, wood and laminates as it kills bacteria. It comes in a 750ml dual nozzle trigger spray, a direct stream and an atomiser spray.



**NEW**

Type	Size	Order Code
Trigger Spray	750ml	<b>-3040D</b>

**Contract Pine Disinfectant**

For general cleaning with a pleasant pine fragrance.



Type	Size	Order Code
Poly-bottle	5ltr	<b>-3003P</b>

**Stainless Steel Cleaner**

Silicone-free cleaner polish. For rapid cleaning and polishing of all stainless steel, chrome, aluminium, laminates and enamel. Ideal for serveries, kitchen appliances, food displays.



Size	Order Code
750ml	<b>-3026N</b>

**Window Cleaner**

Simply spray on and wipe off to leave windows clean and sparkling. Contains vinegar for extra cleaning and a demisting additive.



Size	Order Code
750ml	<b>-3025M</b>

**Chanel-Blox**

Deodorant cubes for use in urinal bowls and channels. Supplied in plastic tub.



Product	Size	Order Code
Chanel-Blox	3kg	<b>-2710D</b>

**PDCB FREE**

**PACK OF 150**

**Concentrated Thick Bleach**

Powerful thick formula effective against all pathogenic organisms. Contains added detergents for improved cleaning.



Type	Size	Order Code
Poly-bottle	1ltr	<b>-2914Y</b>
Poly-bottle	5ltr	<b>-3007T</b>

**All Fresh Washroom Cleaner**

General-purpose cleaner/disinfectant for use on hard surfaces. Prevents limescale build-up on vitreous enamel and stainless steel surfaces.



Size	Order Code
1ltr	<b>-2915Z</b>

**Furniture Polish**

Cleans and shines with a wipe. To clean, shine and protect furniture, tile, marble, stainless steel and most plastic and vinyl-coated materials.



Size	Order Code
750ml	<b>-3024L</b>

**Medium Strength Toilet Cleaner**

For cleaning and descaling ceramic sanitary fittings including urinals, WCs and wash basins. Suitable for industrial household, recreational, leisure and toilet/washroom facilities.



Product	Size	Order Code
Toilet Cleaner	1ltr	<b>-2912W</b>
	5ltr	<b>-3004Q</b>



**Washing-Up Detergent**

**Contract**

A fully biodegradable 15% high active detergent for use as dishwashing liquid and general cleaning.



Strength	Size	Order Code	
Contract	5ltr	<b>SOL-780</b>	
		<b>-3005R</b>	<b>N/A</b>

**Washing-Up Detergent**

**Professional**

A highly concentrated (up to 30%) liquid for hand dishwashing and general cleaning.



Strength	Size	Order Code	
Professional	5ltr	<b>SOL-780</b>	
		<b>-3008V</b>	<b>N/A</b>

**All-Purpose Cleaner**

**Professional**

A thick lemon scented gel for use on all hard surfaces, walls, vinyl seats and coverings.



Strength	Size	Order Code	
Professional	5ltr	<b>SOL-780</b>	
		<b>-3011Y</b>	

**Professional Floor Cleaner Gel**

Pine oil-based gel for maintaining hard floor surfaces, including wood block, lino, vinyl and terrazzo. Can be buffed to a high gloss, non-slip sheen.



Type	Size	Order Code	
Poly-bottle	5ltr	<b>SOL-780</b>	
		<b>-3010X</b>	

**Laundry Powder**

Fresh fragrance for whites and coloured fabrics. For automatic and top loading machines.



Product	Qty	Order Code	
Biological	10kg	<b>SOL-780</b>	
		<b>-4010A</b>	

**Lemon Quest Washing Up Liquid**

Concentrated to last. For use as dishwashing liquid and general household cleaning.



Type	Size	Order Code	
Lemon	1ltr	<b>SOL-780</b>	
		<b>-2910T</b>	<b>N/A</b>

**Gel Air Freshener**

Concentrated 2-in-1 gel air freshener which freshens and fragrances leaving a floral or ocean fresh fragrance.

**NEW**



Fragrance	Order Code	
Floral	<b>SOL-780</b>	
Ocean	<b>-3029D</b>	<b>-3029H</b>

**Air Fresheners**

300ml aerosol room fresheners replaces offensive odours with a pleasant scent.



Description	Order Code	
Pot Pourri	<b>KEN-722</b>	
Wild Berries	<b>-1500K</b>	<b>-1510K</b>
Scented Jasmine	<b>-1520K</b>	

**Concentrated Hard Surface Cleaner/Degreaser**

Diluted with up to 50 parts of hot or cold water. Rapidly breaks down grease and fat. Apply by hand scrubbing, mopping, power wash systems or mechanical floor scrubbing machines. Can be used on concrete floors, walls, paintwork, components etc.



Type	Size	Order Code	
Poly Bottle	5ltr	<b>SOL-780</b>	
Plastic Drum	20ltr	<b>-6300A</b>	<b>-6310B</b>

**Traffic Film Remover Concentrate**

Effectively removes dirt, grime, grease and tenacious traffic film from all vehicles. Suitable for cleaning chassis and bodywork on vehicles. Designed for high pressure washing with mechanical power wash systems. Concentrated formula can also be used to clean machinery, floors, walls, asphalt, will also remove co-polymer waxes used in new car production.



Type	Size	Order Code	
Poly Bottle	5ltr	<b>SOL-780</b>	
Plastic Drum	20ltr	<b>-6400A</b>	<b>-6410B</b>

**Wash & Wax Vehicle Shampoo**

High foam, high gloss vehicle shampoo. Mild formula, neutral pH, water-based. Effectively lifts traffic film without harm to polished paintwork and trim. With foam boosters for fast removal of dirt and grease. High gloss wax finish. Can be used with hot or cold pressure washing systems or hand washing. Easy to handle container.



Type	Size	Order Code	
Poly Bottle	5ltr	<b>SOL-780</b>	
Plastic Drum	20ltr	<b>-6500A</b>	<b>-6510B</b>

**IDEAL FOR CARAVANS AND MOBILE HOMES**

**LUBRICANTS & CHEMICAL PRODUCTS**